

Build a Cell Balancer

Why balance your cells?

All cells have slightly different capacities and internal resistances. They will also self-discharge at different rates when stored. This means that when you start to charge your cells some may be completely discharged and others will contain varying degrees of residual charge.

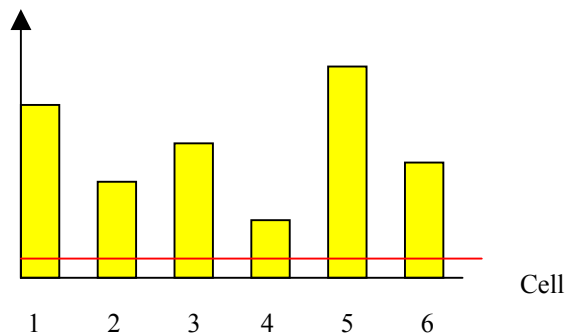

When the pack is recharged, a peak detect charger will find it difficult to detect when the pack has reached its peak and is likely to overcharge some cells and under-charge others. The result will be that not all the cells are operating at their maximum capacity.

Balancing

To balance a pack we need to discharge all the cells individually to the same level. Cell manufacturers do not recommend discharging down to zero volts so we need a method of discharging down to a minimum voltage. A diode typically needs 0.6v across its terminals before it starts to conduct, so it is used to prevent the cells discharging completely. The balancer uses a diode and resistor in series across each cell.

Balancer design

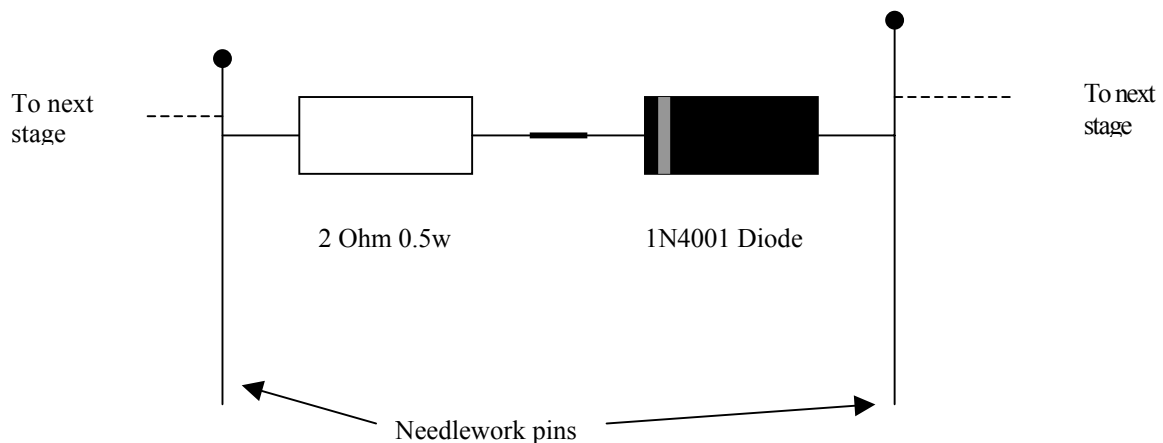

My balancer is made up from a series of identical cell dischargers arranged in a chain.

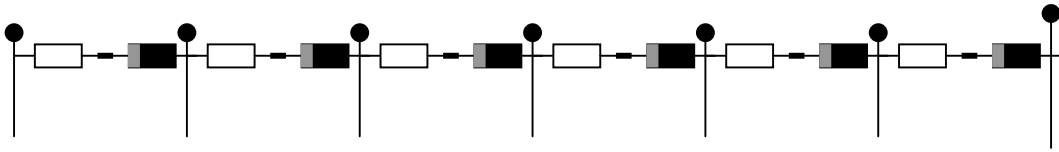

Construction

Solder the lead at the anode of the diode (stripe end) to one of the resistor leads.

Solder the other end of each component to a pin. Repeat the process until you have built up a chain as shown in the diagram.

If you cant get a 2-Ohm .5w resistor, you could use a more common 10-Ohm 1/8 w resistor but the balancing process will take a little longer.

Connecting the balancer to a battery pack

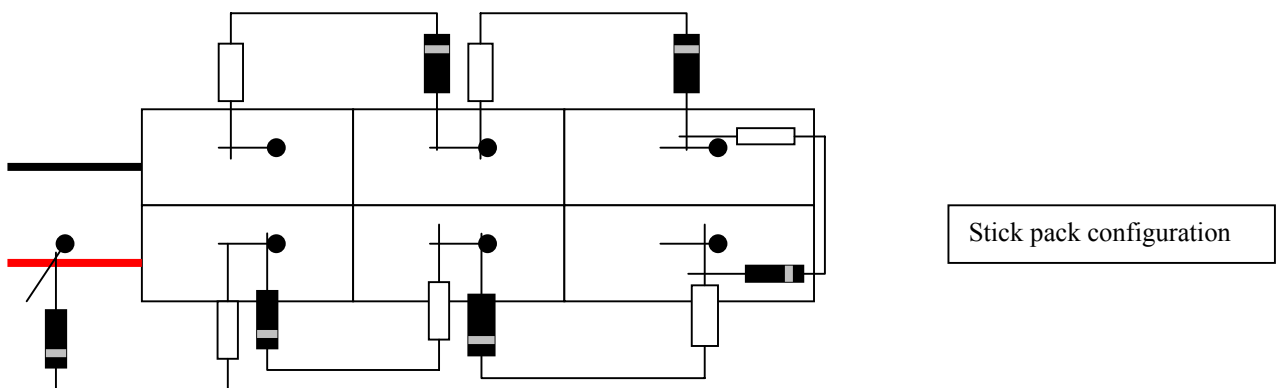
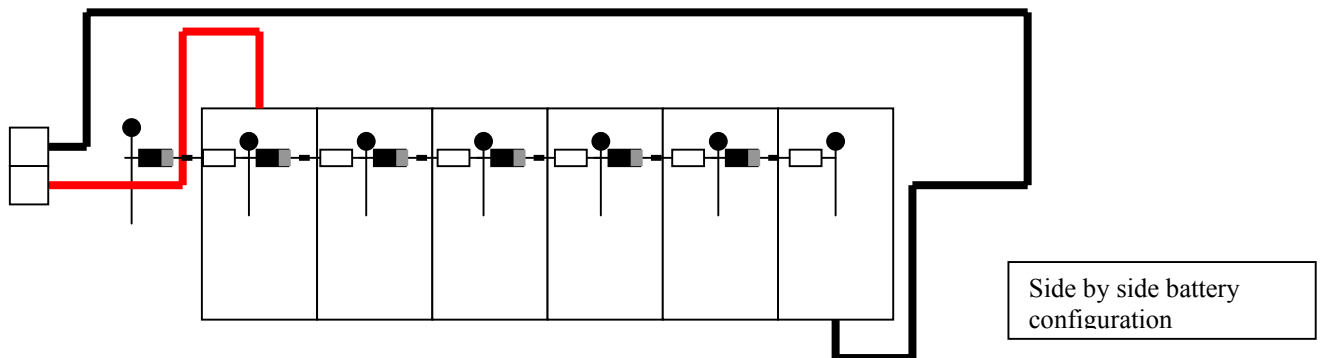

The first pin should be inserted in the positive lead of the battery pack

The second pin is inserted a shallow angle between the outer sleeve of the first cell and the its metal body.

The stripe on the diode must point towards the first cell otherwise the diode will not conduct and the cell will not discharge.

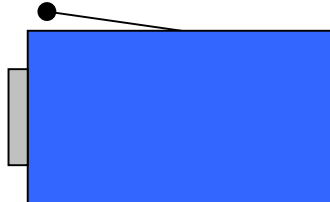

To check that you have a good connection between the cells, check that a small voltage (0.5 – 1.4v) exists between the pins.

Continue by connecting each cell in turn as shown in the diagram with the stripe on each diode pointing away from the positive lead.

Checking

In most cases the pack will be reasonably well balanced after a couple of hours (although I normally leave mine overnight). The balancer should not damage the pack if it is left connected, as the diodes will prevent it discharging below .6v per cell. You can check the progress of the balancing process by measuring the voltage of each cell using a multimeter (voltage measured between pins). The pack will be well balanced when all cells measure less than 1v.